

NP100-II is a high capacity baler, easy to operate. The unique quiet screw drive provides a powerful compaction with heavy bale weight. The generous infeed is ideal for larger boxes and handles large volumes every time.

Customizable technical solutions:

Plug'n Press - the modern control system surveys starting-up and operation.

Stay'n hold - the press ram stops in compaction mode (with full press power), giving more compact bales. Suitable for material that raise up. During 'Stay'n hold' no electricity is needed.

Autostart - the baler starts compacting automatically when the feed door is closed.

- ▶ Compacts most material: paper, cardboard, soft and hard plastic etc.
- ▶ High compaction pressure and generous feed opening on a minimum of floor space
- ▶ Convenient feed height
- ▶ Total height only 2,07 m!
- ▶ Very reliable, proven long-lasting performance, even out-doors
- ▶ Silent running electromechanical baler
- ▶ No hydraulic oil



*Efficient feeding of material thanks to the feed door that pushes the material into the chamber at closing.
NP100-II can be easily relocated by a pallet truck and placed near the source of material. A flexible and sustainable solution good for both environment and economy.*

Distinctness



The control system gives a distinct indication of operating status.

Efficiency



All operation from the front, as feeding of material and bale ejection. The feed door can be opened 90° or, as in the photo, all the way down 180°.

The four bale strapping rolls are placed under the red top cover and can be replaced separately.

Capacity



NP100-II compacts effectively a great volume of material thanks to the generous press chamber.

Eight moveable scrapers keep the material compacted without tearing grooves.

Volume reduction



The bale is tied with four straps and easily removed by the safe built-in 2-hand manoeuvred ejection system.

The volume is reduced by up to 95%!

NP100-II

the heavy-duty baler

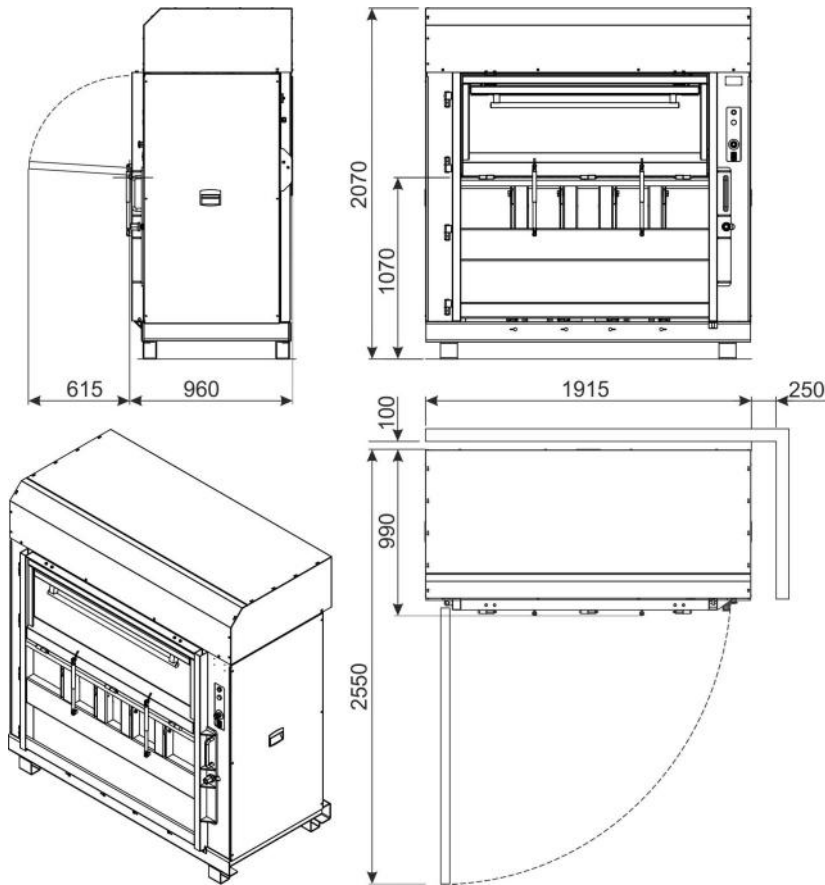

By a pallet truck the machine can be moved from side or front - rationally for placement and simplifies cleaning.



Since the mid-sixties more than 15,000 balers have been delivered all over the world.



Components from global world class suppliers ensure quality and availability.



Our continuous development in close co-operation with users world wide gives us a unique knowledge of compacting and recycling.

The result is an outstanding range of products representing good design with excellent performance.

All compactors from NVA carry the CE-mark.



Model	Pressure kN	Weight kg	Feed opening mm	Bale size mm			Bale weight kg	dB(A)
				Length	Width	Height		
NP100-II	250	1212	1500 x 550	1500	800	800-900	350 - 550	60

Voltage: 3-phase 400 V, 50 Hz in standard version. Other voltages available.
 NP100-II is one of the balers in our range - please contact us for more information of other products!
 We reserve the right to introduce technical alterations.



NordTech Consulting & Trading Company

Address: Norra Storangsvägn 38
 SE-612 42 Finspång - Sweden
 Telephone: +46-122273337 / +46-763188020
 E-mail: info@nordtechconsulting.se
 Website: www.nordtechconsulting.se

