

The NP60-II is safe, quiet, fast and efficient. Easy infeed thanks to the large feed opening. The high pressure of 15 tonnes provides excellent compression also of rigid cardboard boxes.

Load the waste through the feed opening, close the feed door and the waste is compacted. When the bale is ready to be ejected a lamp is lit. The built-in bale ejection makes it easy to eject the bale.

Customizable technical solutions:

Plug'n Press - the modern control system surveys starting-up and operation.

Stay'n hold - the press ram stops in compaction mode (with full press power), giving more compact bales. Suitable for material that raise up. During 'Stay'n hold' no electricity is needed.

Autostart - the baler starts compacting automatically when the feed door is closed.

- ▶ Compacts most material: paper, cardboard, soft and hard plastic etc.
- ▶ High compaction pressure and generous feed opening on a minimum of floor space (<1 m²)
- ▶ Convenient feed height, lower than 82 cm
- ▶ Total height 1,85 m!
- ▶ Very reliable, proven long-lasting performance, even out-doors
- ▶ Silent running electromechanical baler
- ▶ No hydraulic oil



Thanks to its low height, the NP60-II can be placed near the source and can easily be relocated with a pallet truck by changing needs.

Distinctness



The control system can easily provide additional features for customized solutions.

Efficiency



Efficient sorting near the source. The NP60-II is silent-running and provides a good work environment.

Capacity



Low loading height, generous feed volume. Close the feed door for automatic compaction.

Volume reduction



A volume reduction of up to 95%! The built-in ejection device simplifies the ejection of bale.

NP60-II baler

- no waste of space -

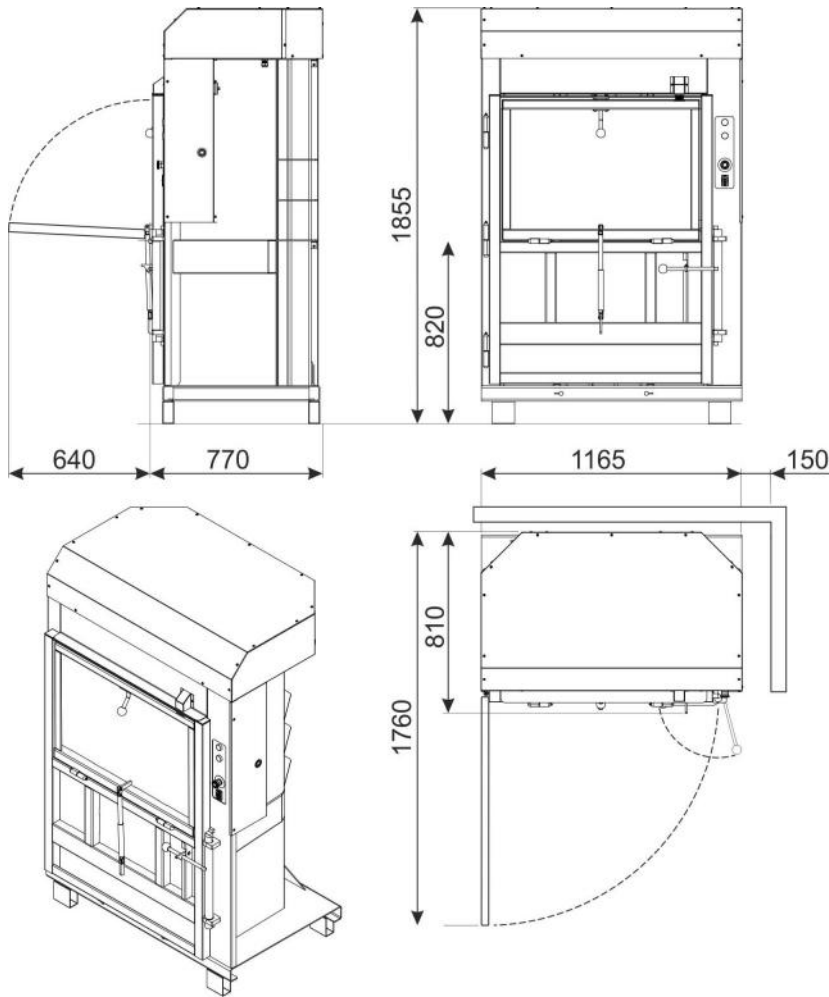

The feed door opens 90° as standard, but can be opened all the way down 180° for customized needs.



The bale strapping rolls are easily reached at the front. Each roll can be replaced separately.



Since the mid-sixties more than 15,000 balers have been delivered all over the world.



Our continuous development in close co-operation with users world wide gives us a unique knowledge of compacting and recycling.

The result is an outstanding range of products representing good design with excellent performance.

All compactors from NVA carry the CE-mark.



Model	Pressure kN	Weight kg	Feed opening mm	Bale size mm			Bale weight kg	dB(A)
				Length	Width	Height		
NP60-II	150	500	900 x 600	900	500	700-800	60 - 120	57

Voltage: 3-phase 400 V, 50 Hz in standard version. Other voltages available.
NP60-II is one of the balers in our range - please contact us for more information of other products!
We reserve the right to introduce technical alterations.



NordTech Consulting & Trading Company

Address: Norra Storangsvägn 38
SE-612 42 Finspång - Sweden
Telephone: +46-122273337 / +46-763188020
E-mail: info@nordtechconsulting.se
Website: www.nordtechconsulting.se

